

ĐỘNG CƠ ĐIỆN KHÔNG ĐỒNG BỘ 3 PHA Y

Model	Công suất		Dòng điện (A)	Hệ số công suất	Hiệu ứng (%)	Tốc độ vòng quay (r/min)	Momen xoắn mặt định	Dòng điện liên tục (A)	Momen xoắn lớn nhất
	KW	HP							
Y801-2	0.75	1	1.8	0.84	75	2830	2.2	6.5	2.3
Y802-2	1.1	1.5	2.5	0.86	77	2830	2.2	7	2.3
Y801-4	0.55	0.75	1.5	0.76	73	1390	2.4	6	2.3
Y802-4	0.75	1	2	0.76	74.5	1390	2.3	6	2.3
Y90S-2	1.5	2	3.4	0.85	78	2840	2.2	7	2.3
Y90L-2	2.2	3	4.8	0.86	80.5	2840	2.2	7	2.3
Y90S-4	1.1	1.5	2.8	0.78	78	1400	2.3	6.5	2.3
Y90L-4	1.5	2	3.7	0.79	79	1400	2.3	6.5	2.3
Y90S-6	0.75	1	2.3	0.7	72.5	910	2	5.5	2.2
Y90L-6	1.1	1.5	3.2	0.72	73.5	910	2	5.5	2.2
Y100L-2	3	4	6.4	0.87	82	2870	2.2	7	2.3
Y100L1-4	2.2	3	5	0.82	81	1430	2.2	7	2.3
Y100L2-4	3	4	6.8	0.81	82.5	1430	2.2	7	2.3
Y100L-6	1.5	2	4	0.74	77.5	940	2	6	2.2
Y112M-2	4	5.5	8.2	0.87	85.5	2890	2.2	7	2.3
Y112M-4	4	5.5	8.8	0.82	84.5	1440	2.2	7	2.3
Y112M-6	2.2	3	5.6	0.74	80.5	940	2.2	6	2.2
Y132S1-2	5.5	7.5	11.1	0.88	85.5	2900	2	7	2.3
Y132S2-2	7.5	10	15	0.88	86.2	2900	2	7	2.3
Y132S-4	5.5	7.5	11.7	0.84	85.5	1440	2.2	7	2.3
Y132M-4	7.5	10	15.4	0.85	87	1440	2	7	2.3
Y132S-6	3	4	7.3	0.76	83	960	2	6.5	2.2
Y132M1-6	4	5.5	9.4	0.77	84	960	2	6.5	2.2
Y132M2-6	5.5	7.5	12.6	0.78	85.3	960	2	6.5	2.2
Y160M1-2	11	15	21.8	0.88	87.2	2930	2	7	2.2
Y160M2-2	15	20	29.4	0.88	88.2	2930	2	7	2.2
Y160L-2	18.5	25	35.5	0.89	89	2930	2	7	2.2
Y160M-4	11	15	22.6	0.84	88	1460	2.2	7	2.2
Y160L-4	15	20	30.3	0.85	88.5	1460	2.2	7	2.2
Y160M-6	7.5	10	17	0.78	86	970	2	6.5	2
Y160L-6	11	15	24.6	0.78	87	970	2	6.5	2
Y180M-2	22	30	42.2	0.89	89	2940	2	7	2.2
Y180M-4	18.5	25	35.9	0.86	91	1470	2	7	2.2
Y180L-4	22	30	42.5	0.86	91.5	1470	2	7	2.2
Y180L-6	15	20	31.6	0.81	89.5	970	1.8	6.5	2
Y200L1-2	30	40	56.9	0.89	90	2950	2	7	2.2
Y200L2-2	37	50	69.8	0.89	90.5	2950	2	7	2.2
Y200L-4	30	40	56.8	0.87	92.2	1470	2	7	2.2
Y200L1-6	18.5	25	37.7	0.83	89.8	970	1.8	6.5	2
Y200L2-6	22	30	44.6	0.83	90.2	970	1.8	6.5	2
Y225M-2	45	60	84.4	0.89	91	2970	2	7	2.2
Y225S-4	37	50	69.9	0.87	92.5	1480	2	7	2.2
Y225M-4	45	60	84.7	0.87	92.8	1480	2	7	2.2
Y225M-6	30	40	59.3	0.84	91.5	980	1.8	6.5	2

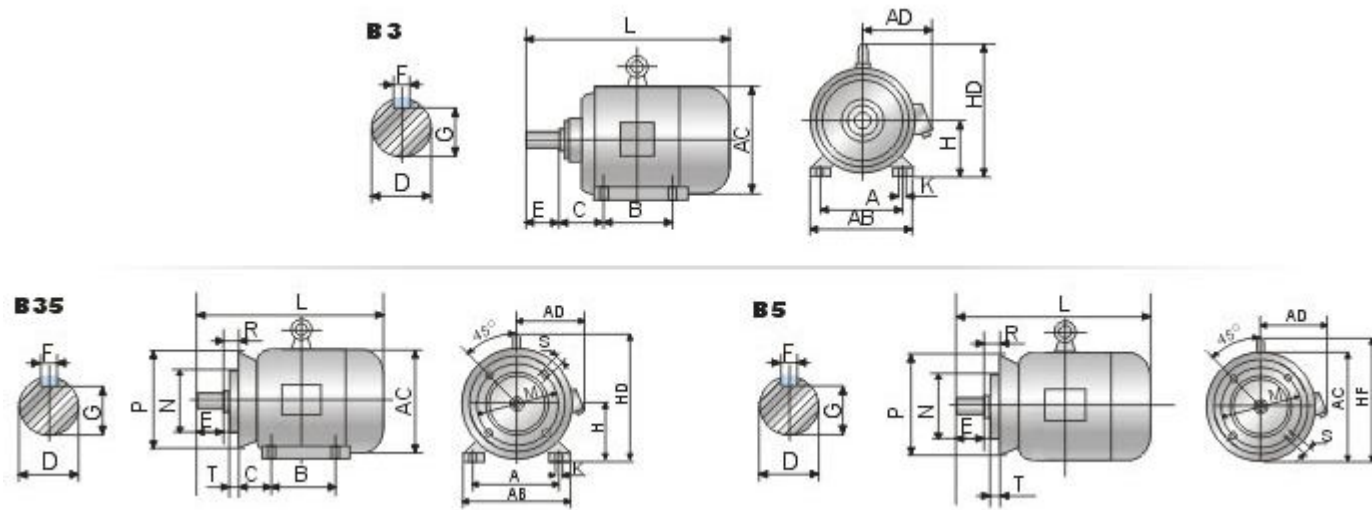

Model	Kích thước lắp đặt (mm)															Kích thước bên ngoài (mm)					
	A	B	C	D	E	F	G	H	K	M	N	P	R	S	T	AB	AC	AD	HD	HF	L
Y80	125	100	50	19	40	6	15.5	80	10	165	130	200	0	12	3.5	165	175	150	175	185	290
Y90S	140	100	56	24	50	8	20	90	10	165	130	200	0	12	3.5	180	195	160	195	195	315
Y90L	140	125	56	24	50	8	20	90	10	165	130	200	0	12	3.5	180	195	160	195	195	340
Y100L	160	140	63	28	60	8	24	100	12	215	180	250	0	15	4	205	215	180	245	245	380
Y112M	190	140	70	28	60	8	24	112	12	215	180	250	0	15	4	245	240	190	265	265	400
Y132S	216	140	89	38	80	10	33	132	12	265	230	300	0	15	4	280	275	210	315	315	475
Y132M	216	178	89	38	80	10	33	132	12	265	230	300	0	15	4	280	275	210	315	315	515
Y160M	254	210	108	42	110	12	37	160	15	300	250	350	0	19	5	330	335	265	385	385	605
Y160L	254	254	108	42	110	12	37	160	15	300	250	350	0	19	5	330	335	265	385	385	650
Y180M	279	241	121	48	110	14	42.5	180	15	300	250	350	0	19	5	355	380	285	430	430	670
Y180L	279	279	121	48	110	14	42.5	180	15	300	250	350	0	19	5	355	380	285	430	430	710
Y200L	318	305	133	55	110	16	49	200	19	350	300	400	0	19	5	395	420	315	475	480	775
Y225S	356	286	149	60	140	18	49	225	19	400	350	450	0	19	5	435	475	345	530	535	820
Y225M-2	356	311	149	55	110	16	49	225	19	400	350	450	0	19	5	435	475	345	530	535	815
Y225M-4.6	356	311	149	60	140	18	53	225	19	400	350	450	0	19	5	435	475	345	530	535	845